

TO SNAP-LOCK IN A $.187 \pm .003$
 (4.75 ± 0.08) DIA. HOLE IN A
 $.031 - .078$ (0.79-1.98) PANEL THICKNESS

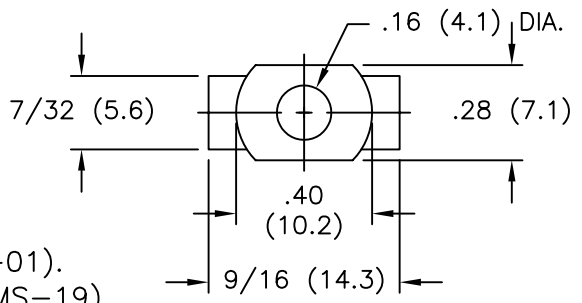
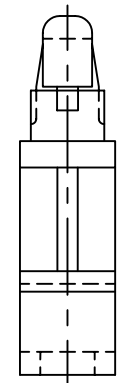
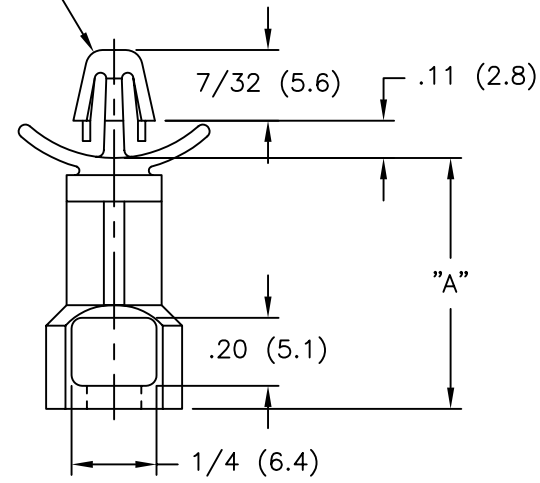

PART NO.	"A"
SRLAHS-7-01	7/16 (11.1)
SRLAHS-8-01	1/2 (12.7)
SRLAHS-10-01	5/8 (15.9)
SRLAHS-12-01	3/4 (19.1)
SRLAHS-14-01	7/8 (22.2)
SRLAHS-16-01	1 (25.4)

USE RICHCO RIVET NO.	FOR CHASSIS THICKNESS
SR-4050	.026-.062 (0.7-1.6)
SR-4060	.062-.105 (1.5-2.7)
SR-4070	.105-.145 (2.7-3.7)
SR-4080	.145-.184 (3.7-4.7)
SR-4090	.184-.223 (4.7-5.7)
SR-4100	.223-.263 (5.7-6.7)
SR-4120	.282-.341 (7.2-8.7)

NOTES:

1. MATERIAL: NYLON 6/6 (RMS-01).
 FLAME RETARDANT NYLON (RMS-19),
 AVAILABLE BY SPECIAL ORDER ONLY.
2. COLOR: NATURAL.
3. $.157 - .161$ (4.0-4.1) DIA. HOLE IN
 CHASSIS REQUIRED FOR APPLICATION

TITLE: SNAP RIVET LOCKING ARROWHEAD SUPPORT					DWG IN IN (MM)	
TOLERANCES UNLESS NOTED .XX=±.010 .XXX=±.005 FRAC=±1/64 ANG=±1°	FILE # SRLAHS	DWN: P.B.	APP:	FINAL		
	MAT'L: SEE NOTES	DT: 05-03-94	DT:	PART #	PRINT TYPE	
	RE: RICHCO, INC.	RICHCO INC. PO BOX 804238, CHICAGO, 60680 (773) 539-4060		SEE TABLE	CA	

REV	DESCRIPTION	ENGR	DATE
C	SEE ECN #1253 FOR CHANGES	SK	11.29.06
B	SEE ECN #1002 FOR CHANGES	SK	05.11.05
A	UPDATED NOTES AND CHANGED FILE NO.	SM	08.20.02